

## Power Quality Improvement In Pv Systems At Distribution Load Level

Sudhakar.Muthyala<sup>1</sup>, Prof. M.V.Ramana Rao<sup>2</sup>

<sup>1</sup>Assistant professor©, EEE, University College Of Technology, O.U.,HYD, Telangana., India  
Sudhakarm37@gmail.com

<sup>2</sup>Assistant professor, EEE,- D University College Of Engg.,O.U.,HYD, Telangana, India  
Ramanarao2@yahoo.co.in

### Abstract:

Electrical utilities and end users of electric power are becoming increasingly concerned about meeting the growing energy demand. Maximum amount of energy demand is supplied by the non-renewable sources, but increasing air pollution, global warming concerns, diminishing fossil fuels and their increasing cost have made it look towards renewable energy sources. This paper presents a grid interfacing inverter that compensates power quality problems and it can also interface renewable energy sources with the electric grid. The grid interfacing inverter can effectively be utilized to perform following functions such as transfer of active power harvested from the renewable resources, load reactive power demand support, current harmonic compensation at PCC and current unbalance and neutral current compensation in case of 3-phase 4-wire system. The converter will therefore be used as: 1) power converter to inject power generated from RES to the grid, and 2) shunt

APF and L,C Filter to compensate current unbalance, load current harmonics, load reactive power demand and cargo neutral current.

**INDEX TERMS-** *power quality (PQ), renewable energy, grid interconnection*

### I. INTRODUCTION

With the drastic increase in areas of air pollution, concerns related to global warming, continuous reduction of fossil fuels and their increasing cost have made it necessary to look towards Renewable Energy Sources (RES) as a forthcoming potential energy solution. In finding solutions to overcome a global energy crisis the Photo Voltaic (PV) system has attracted significant attention in recent years. As the government is providing incentives for further increasing the use of grid connected PV systems the Renewable Energy Sources are increasingly integrated at the distribution level due to increase in load demand utility which utilizes power electronic converters. The Renewable Energy Source (RES) integrated at distribution level is termed as Distributed Generation (DG). The utility is concerned due to the high penetration level of intermittent RES in distribution systems as it may pose a threat to network in terms of stability, voltage regulation and Power -Quality (PQ) issues. Therefore, the DG systems are required to comply with strict technical and regulatory frameworks to ensure safe, reliable and efficient operation of overall network. With the

advancement in power electronics and digital control technology [1][2], the DG systems can now be actively controlled to enhance the system operation with improved PQ at Point of Common Coupling (PCC). However, the extensive use of power electronics based equipment and non-linear loads at PCC generate harmonic currents, which may deteriorate the quality of power. Generally, current controlled voltage source inverters are used to interface the intermittent RES in distributed system. Recently, a few control strategies for grid connected inverters incorporating PQ solution have been proposed. In an inverter operates as active inductor at a certain frequency to absorb the harmonic current.

But the exact calculation of network inductance in real -time is difficult and may deteriorate the control performance. The non -linear load current harmonics may result in voltage harmonics and can create a serious PQ problem in the power system network [3]. Active Power Filter (APF) is extensively used to compensate the load current harmonics and load unbalance at distribution level. Another solution is to incorporate the features of APF in the, conventional inverter interfacing renewable with the grid,

without any additional hardware cost. Here, the main idea is the maximum utilization of inverter rating which is most of the time underutilized due to intermittent nature of RES [4]. The grid-interfacing inverter can effectively be utilized to perform functions as transfer of active power harvested from the renewable resources (wind, solar, etc.), load reactive power demand support, current harmonics compensation at PCC, current unbalance and neutral current compensation in case of 3-phase 4-wire system.

**II. PROPOSED SYSTEM ANALYSIS**

In our proposed system, it is shown that using an adequate control strategy, with a four-leg four-wire grid interfacing inverter, it is possible to mitigate disturbances like voltage unbalance. The topology of the investigated grid interfacing inverter and its interconnection with the grid is presented in Fig. 1

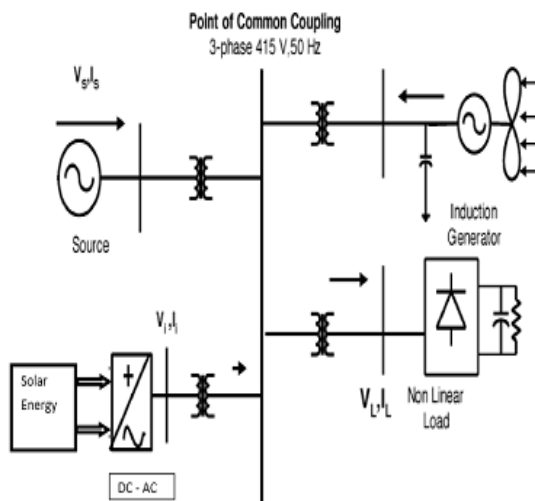

**Fig.1 Single line diagram for Hybrid system**

**A. TOPOLOGY**

This topology has been proved better with respect to controllability [6] than the classical three-leg four-wire here in this paper it is shown that by adapting an adequate control strategy even with a three phase four wire system the topology of the investigated APF and its interconnection with the grid is presented in fig. 1 and it consists of a three-leg four-wire voltage source inverter where the VSI operates as a current controlled voltage source in this application and the proposed system is a Three Phase Four wire which consists of Photovoltaic system connected to the dc-link of a grid-interfacing inverter

**B. VOLTAGE SOURCE CONVERTER (VSC)**

A Voltage Source Converter (VSC) is a power electronic device that is connected in shunt or parallel to the system which is used to generate a sinusoidal voltage with any required magnitude or frequency and phase angle. And it also converts the DC voltage across storage devices into a set of three phase AC output voltages and also it is capable of generating or absorbing reactive power when the output voltage of the VSC is greater than AC bus terminal voltages which is said to be in capacitive mode and it will compensate the reactive power through AC system and the type of power switch used is an IGBT in anti-parallel with a diode and the three phase four leg VSI is modeled in Simulink by using IGBT.

**C. SWITCHING CONTROL**

The standing of the switches is set in line with the error. once this is increasing and therefore the error exceeds a particular positive price, the standing of the switches changes and therefore the current begins to decrease till the error reaches a particular negative price. Compared with linear controllers, the non-linear ones supported physical phenomenon ways enable quicker dynamic response and higher hardness with relevance the variation of the non-linear load as shown in fig.2

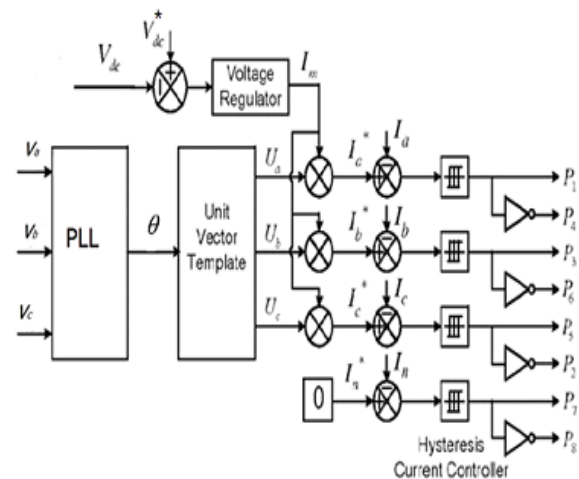
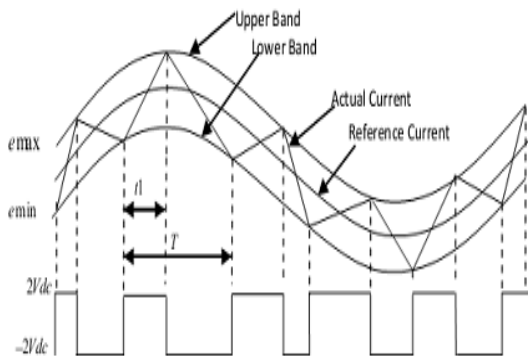

**Fig 2. Control Scheme**

**D. HYSTERESIS CURRENT CONTROL**

As shown in Fig .3. miscalculation signal is employed to manage the switches in an exceedingly voltage supply electrical converter. If the error exceeds the higher limit of the physical phenomenon band, the higher switch of the electrical converter arm is turned off and therefore

the lower switch is turned on. As a result, this starts decaying.

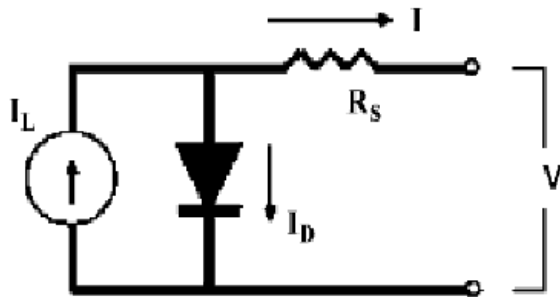

**Fig 3. Waveform of Hysteresis current controller**

If the error crosses the lower limit of the physical phenomenon band, the lower switch of the electrical converter arm is turned off and therefore the higher switch is turned on. As a result, this gets back to the physical phenomenon band.

**E. MODELING THE PV ARRAY**

A PVG consists by several strings of star cells asynchronous, connected in parallel, so as to produce the required values of output voltage and current as shown in fig.4



**Fig 4. Solar-Cell Equivalent Circuit.**

**III. WIND TURBINE SYSTEM MODELLING**

Generally, a whole turbine model consists of Associate in Nursing mechanics model, mechanical drive model, and induction generator model.

The mechanics rotor extracts the kinetic power from the wind and exchanges this power into mechanical power. The relation between the wind speed and mechanical power is given by Equation

$$P_w = (1/2) \rho \pi R^2 V_w^3 C_p(\theta, \delta) \dots\dots\dots (1)$$

where,  $P_w$  is the power extracted from wind (W),  $\rho$  is the air density (kg/m<sup>3</sup>),  $R$  is the radius of the rotor of wind turbine (m),  $V_w$  is the wind speed ( m/s ),  $\theta$  is the pitch angle of the rotor (deg) ,  $\lambda = W_{rot} R/V_w$ ,  $\lambda$  = the tip speed ratio, where,  $W_{rot}$  is the rotor speed of wind turbine (rad/sec),  $C_p$  is the aerodynamic efficiency of the rotor which can be expressed as a function of the tip speed ratio ( $\lambda$ ) and the pitch angle ( $\theta$ ) by the following equation

$$C_p = 0.22(116/\beta - 0.40 - 5) e^{-12.5/\beta} \dots\dots\dots (2)$$

Produced mechanical power is transferred into the electrical energy by generator and is fed into the grid.

**A. CONTROL OF WIND FARM SIDE CONVERTER**

The simplified management diagram of the powerhouse aspect device is additionally enclosed in grid aspect. Shift signal is that the point order in degrees derived from open loop power controller. It's the angle by that the voltage across thecausation finish electrical device is section shifted so as to manage the facility flow shown in fig.5.

**B. CONTROL OF GRID SIDE CONVERTER**

This management aims to regulate the point of receiving finish device at the AC aspect. Also, once the DC link voltage is above traditional condition, the point is adjusted to push power into the receiving finish AC system.

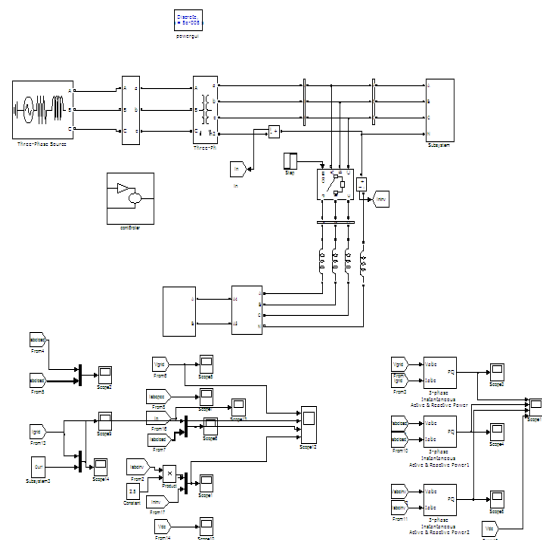

**Fig.5 Simulation Diagram of farm side converter**

### C. POWER QUALITY IN POWER DISTRIBUTION SYSTEMS

Voltage quality issues relate to any failure of kit because of deviations of the road voltage from its nominal characteristics. Power quality issues area unit common in most of business, industrial and utility networks. Natural phenomena, like lightning area unit the foremost frequent explanation for power quality issues. switch phenomena leading to oscillating transients within the electrical offer, for instance once capacitors area unit switched, conjointly contribute well to power quality disturbances.

### III. SIMULATION RESULTS

The total active and reactive powers of grid, load and electrical converter within the APF mode of operation, the electrical converter consumes a little quantity of active power to keep up the dc-link voltage and to beat the losses related to electrical converter, whereas most of the load reactive power want is supported by electrical converter effectively. The performance of the proposed structure is assessed by a computer simulation that uses MATLAB Software. The proposed system is implemented in the academic environment and the results generated in the computer simulation using MATLAB Software are displayed below:

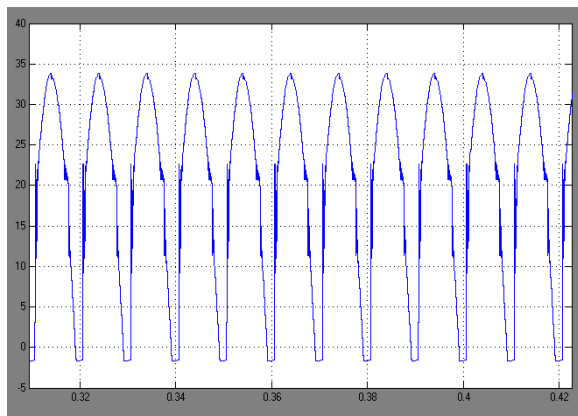

**Fig. 6 Simulation results power factor for Unbalanced Nonlinear Load**

To achieve balanced sinusoidal grid currents at unity power factor, the 4-leg grid interfacing inverter is actively controlled under non varying renewable generating condition. The wave forms of grid voltages, grid currents, unbalanced load current and inverter currents under absence of inverter and presence of inverter are shown in fig.7

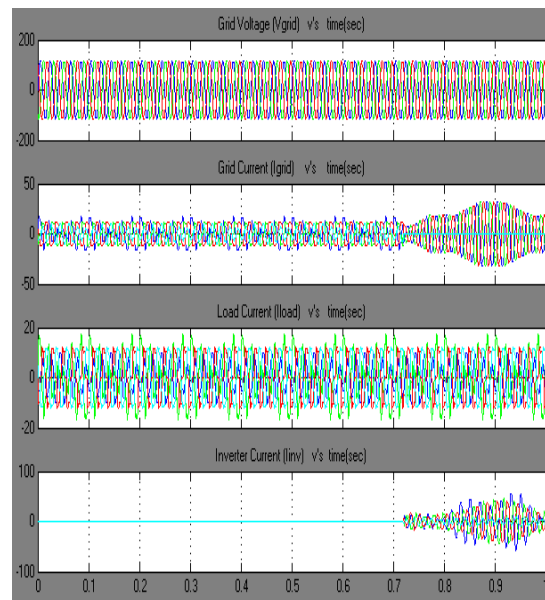

**Fig.7. simulation results a) grid voltages, b) grid currents, c) load currents, d) inverter currents using PI controller**

The corresponding active and reactive powers of grid (PQ grid), load (PQ load) and inverter (PQ inv) under absence of inverter and presence of inverter are shown in fig.8 .

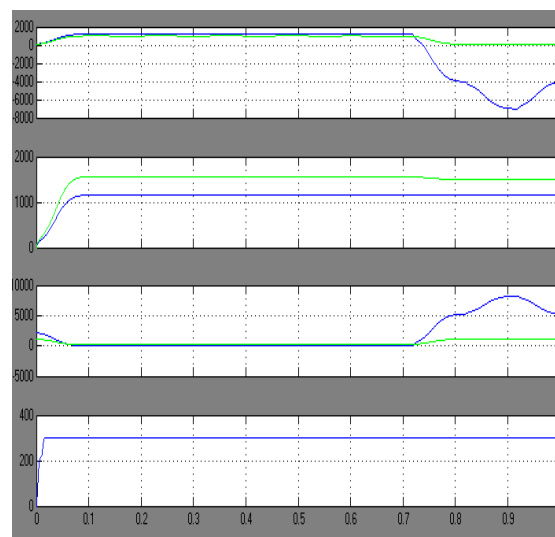

**Fig.8. Simulation results a) PQ-grid, b) PQ-load, c) PQ - inv, d) dc link voltage under no voltage variations from RES**

The speedy switch offers an outsized reduction in lower order harmonic current compared to the road commutated device, however the output current can have high frequency current and might be simply filter-out as shown in Fig.9

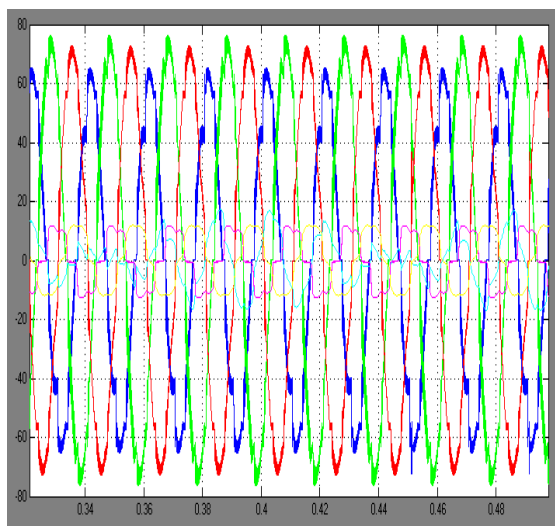

**Fig.9 Load side Output wave form with hybrid filter**

#### IV. CONCLUSION

Our proposed paper has presented the novel control of an existing grid interfacing inverter to improve the quality of power at PCC for a 3-phase 4-wire DG system and it has been shown that the grid-interfacing inverter can be effectively utilized for power conditioning without affecting its normal operation of real power transfer and the proposed approach can be utilized to:

- i) To inject the real power generated from RES to the grid and/or,
- ii) To operate as a shunt Active Power Filter (APF).

This approach eliminates the need of additional power conditioning equipment to improve the quality of power at PCC by extensive use of MATLAB/Simulink simulation based experimental results illustrate the proposed approach and have shown that the grid interfacing inverter can be utilized as a multi-function device.

#### REFERENCES

- [1]. S.K.Khaden, M.Basu, M.F.Conlon, "Power quality in grid connected renewable energy systems: Role of custom power devices". ICERPQ, Granda, Spain, Mar -2010.
- [2]. Dr.Jazeri, Dr.B.Mozafari, "A Novel DG grid interface control strategy for active power injection management and power quality improvement" IPSC, Tahrán, Iran, Nov -2011.
- [3]. A.Arulampalam, M.Barnes, A.Engler, "Control of power electronics interfaces in distributed generation micro grids" IJE, vol.5, 2004., page no.1 -21.

- [4]. Ionel VECHIU, Gelu GURGUIATU, Emil ROSU, "Advanced Active Power Conditioner to Improve Power Quality in Microgrids" IPEC., IEEE Conf., 2010.
- [5] Design And Implementation Of A Current Controlled Parallel Hybrid Power Filter Vishal Verma, Member, And Bhim Singh, Senior Member, IEEE Transactions On Industry Applications, September/October 2009
- [6] A Hybrid Passive Filter Configuration For Var Control And Harmonic Compensation Abdelhamid Hamadi, Student Member, IEEE, Salem Rahmani, Member, IEEE, And Kamal Al-Haddad, Fellow, IEEE Transactions On Industrial Electronics, July 2010
- [7] Mehmet Ucar, Sule Ozdemir, "3-Phase 4-leg unified series-parallel active filter system with ultra capacitor energy storage for unbalanced voltage sag mitigation" Electrical Power and Energy Systems 2013.
- [8]. M.Singh, V.Khadkikar, A.Chandra, Rajiv K.Varma, "Grid interconnection of renewable energy sources at distribution level with power quality improvement" vol.26., no.1., Jan -2011.
- [9] Rachid Dehni, Brahim Ferdi "STATCOM Dc-bus Voltage Controller Based on Fuzzy logic" IJAEST vol.11., pp.281-285.
- [10] M.Bhanu Siva, M.R.P Reddy, Ch.Rambabu "Power Quality Improvement of Three-phase four-wire DSTATCOM with Fuzzy logic Controller" ICSIT., vol.2, pp. 2273-2273., 2011.

#### BIODATA AUTHOR 1



**SUDHAKAR. MUTHYALA** Assistant professor(c) in EEE Dept., U.C.T –O.U Hyderabad Telangana,

#### AUTHOR 2

**Prof.M.V.RAMANA RAO**, Assistant Professor in EEED, OUCE, -OU, Hyderabad, Telangana